



SK-34A-S2

USER MANUAL

I. INTRODUCTION

1.1 Key Features

- 4 x 3.5" SAS and/or SATA hard disk drive (HDD) converted into 3 x 5.25" ODD
- 3Gb/s, 6Gb/s and SGPIO interface compliance
- One SFF8087 mini SAS 4i connector
- Direct HDD Activity/Fault LEDs signal input
- HDD Activity LEDs directly from SAS/SATA HDD
- Buzzer alarm
- Power On, Fan Fail, Over Temperature LED indicator
- Temperature Controlled Fan

1.2 List of Components

The package contains the following items:

- One rear fan (8025mm)
- One set of 4 HDD trays
- Bag of mounting screws
- Two LED signal cables

1.3 Front Panel Features

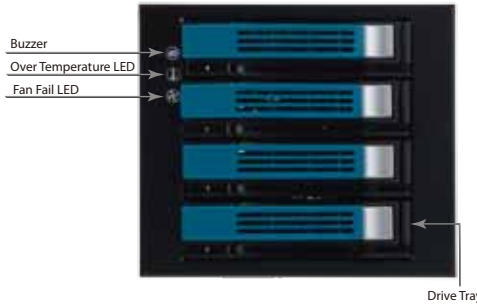

1.3.1 Front view of 3 to 4 storage kit

1.4 Rear Panel Features

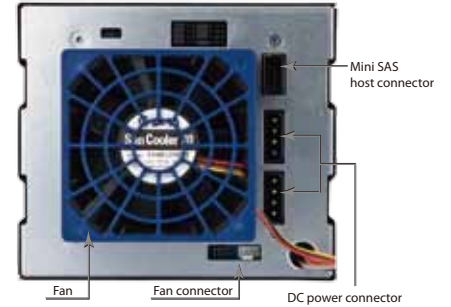

1.4.1 Rear view of 3 to 4 storage kit

1.5 Backplane Setting / Configuration

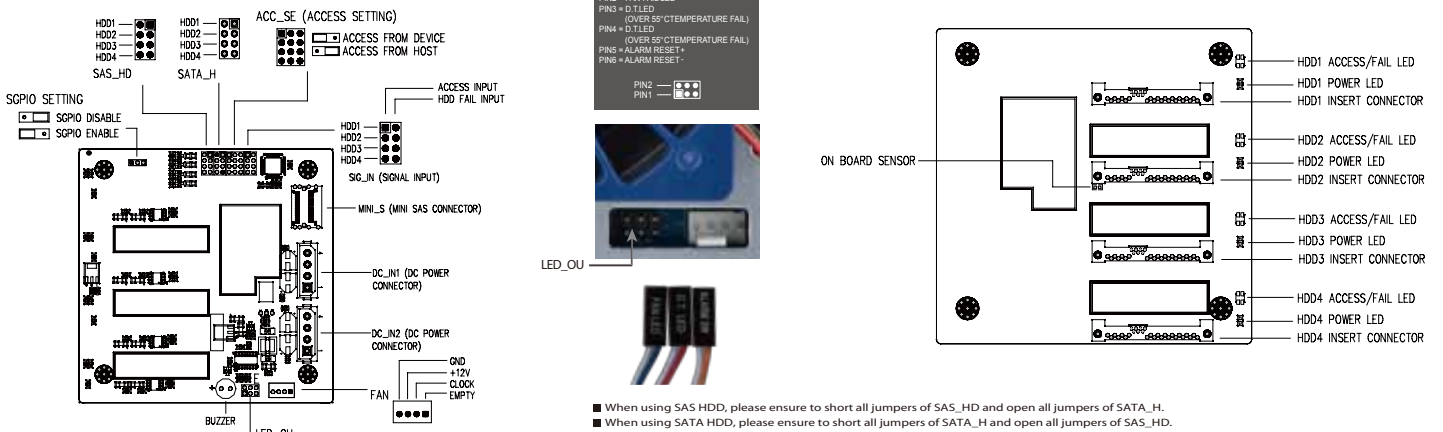

II. INSTALLATION

2.1 HDD Installation

1. Push the latch to the right with your thumb to release the handle.



2. Use the handle to gently pull the HDD tray from the drive bay.



3. Secure the HDD into the tray by using four mounting screws as shown below.

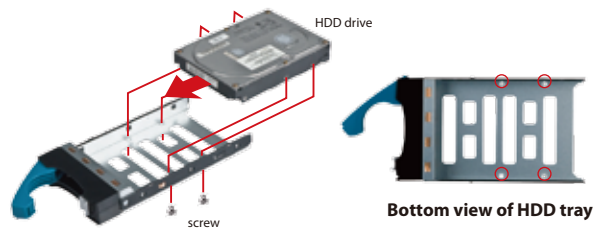

4. Slide the HDD tray into the drive bay slot until the handle is locked.



5. Repeat the steps 1 to 5 for all remaining HDD trays.